



PRODUCT INFORMATION

Evaporator Model	CTD4.1/352H-HCC			
Type	Direct Expansion (DX)			
Refrigerant	R404A			
Selection condition	SC1	SC2	SC3	SC4
	(Te = 0°C, RT= 10°C)	(Te = - 8 °C, RT= 0°C)	(Te = - 25 °C, RT=-18°C)	(Te = - 31 °C, RT= -25°C)
Cooling Capacity	8.59kW	5.57kW	4.17kW	3.21kW
Surface Area	23.05m ²			

TECHNICAL DETAILS

Fin Material	Aluminium
Fin Spacing	7 mm
Tube Material	Copper
Tube Volume	6.9 L
Casing	G.I Powder coated

FAN & AIR FLOW

No. of fans	2
Fan Diameter	300 mm
Speed per fan	1380 rpm
Electric Power / fan	130 W
Air Flow	3700 m ³ /h
Air Throw	13 m

DEFROSTING

Defrosting type	Electric
Coil Heater	2000W
Tray Heater	860W

DIMENSIONS

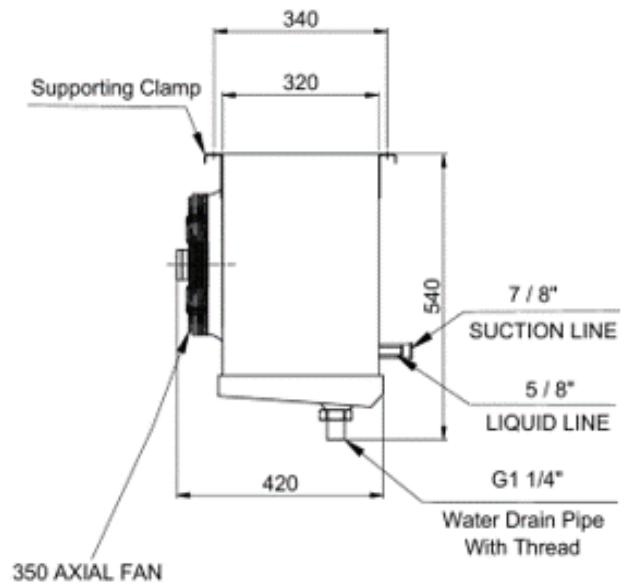
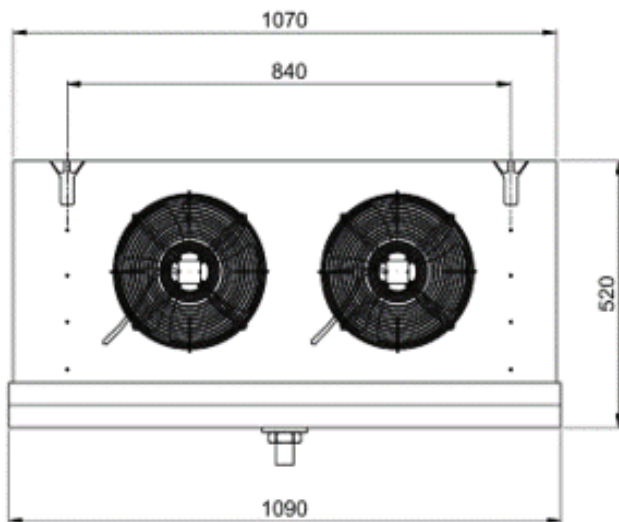

All Dimensions are in mm.

NOTE:

- ❖ The actual air throw varies with product loading and several other factors.
- ❖ It is advised that the unit should not be used in a corrosive atmosphere.
- ❖ All data are subjected to change without prior notice.
- ❖ The fan and heater data could change slightly depending on the manufacturer's design and data changes.
- ❖ The technical and commercial information provided in this data sheet is a property of ColdTech Group, UAE info@coldtechgroup.com